

Drawing Name: Y:\Work\100-02-City Maps\1000 Maps\General CP Map 2-1-08.dwg Mar 02, 2009 - 11:40am

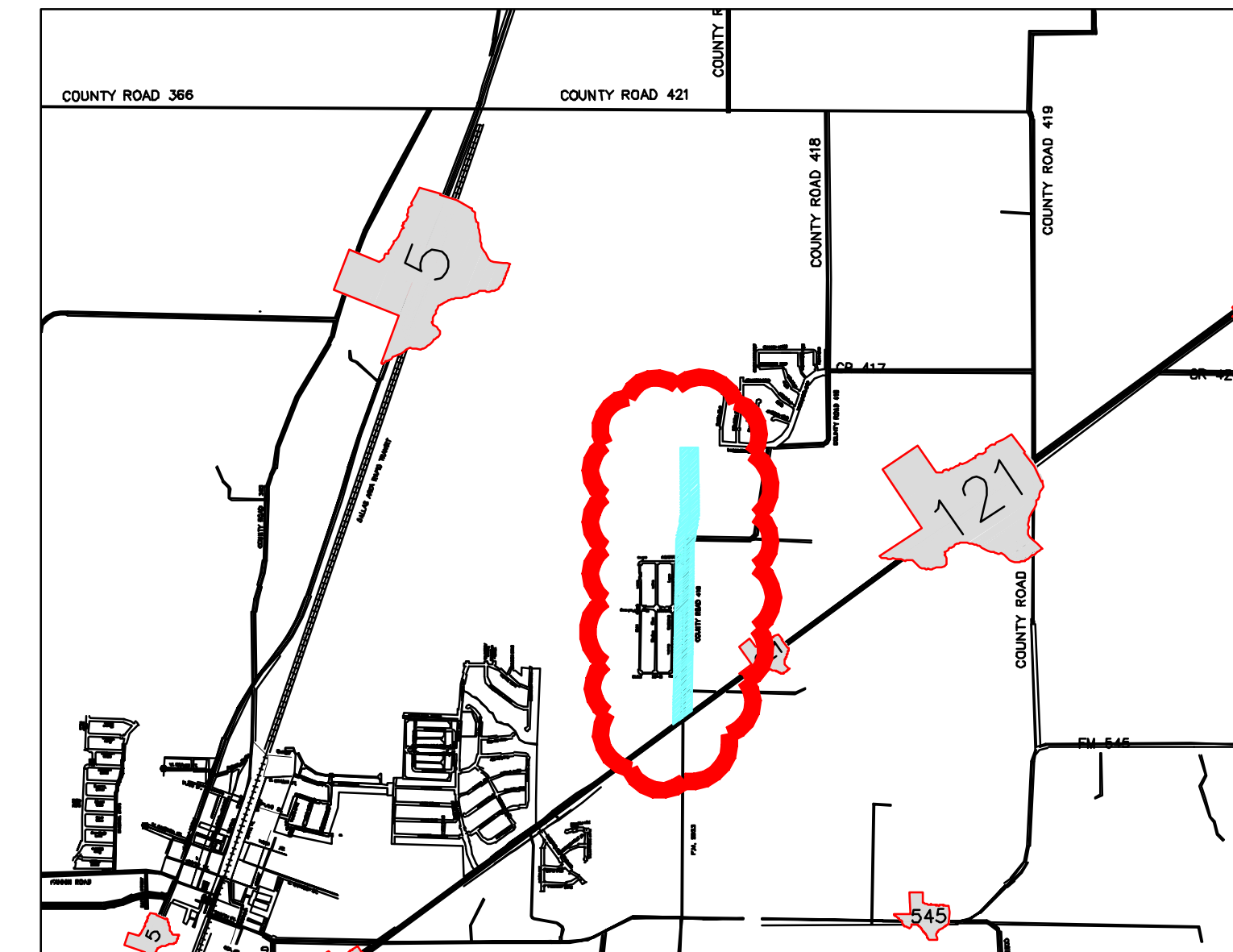

300' CORRIDOR
EXACT ALIGNMENT TBD

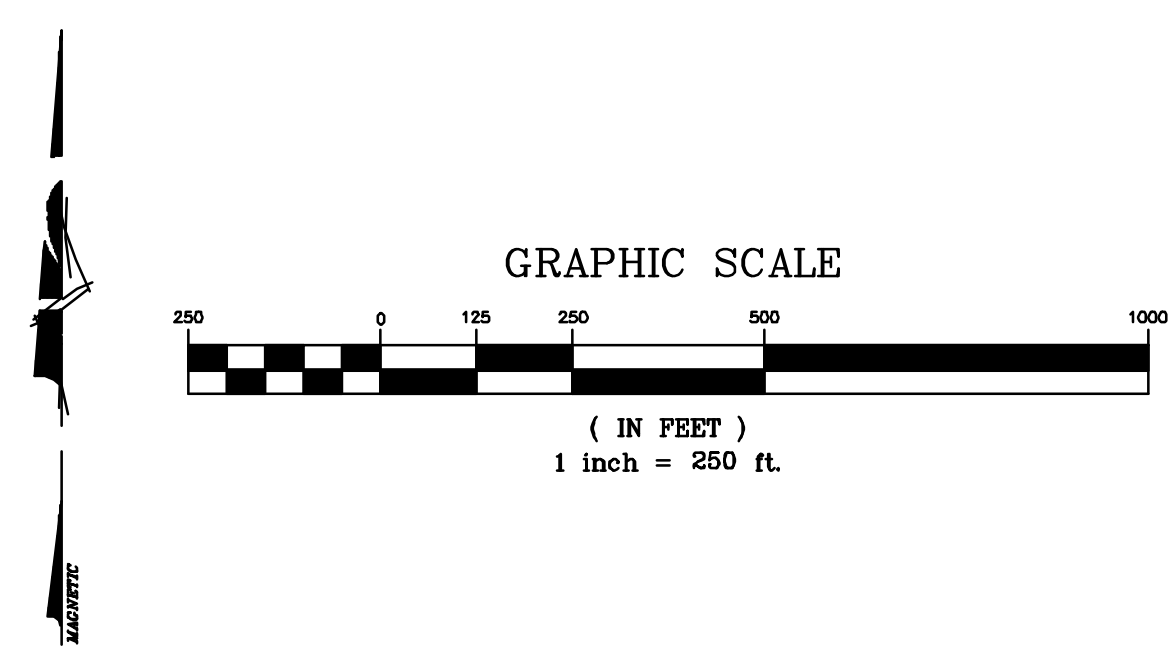
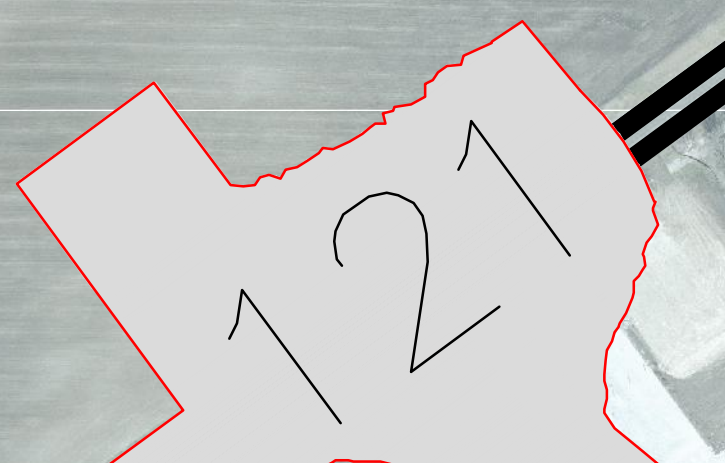

PROJECT LOCATION
N.T.S.

County Rd. 418 – SH121 to Throckmorton

- Three lane collector roadway
- Engineering, ROW acquisition, and construction
- Significant funding from surrounding developers
- Provides vital link from Throckmorton Rd. to SH121
- Needed to accommodate existing and proposed residential growth in area.
- Signalization at SH121

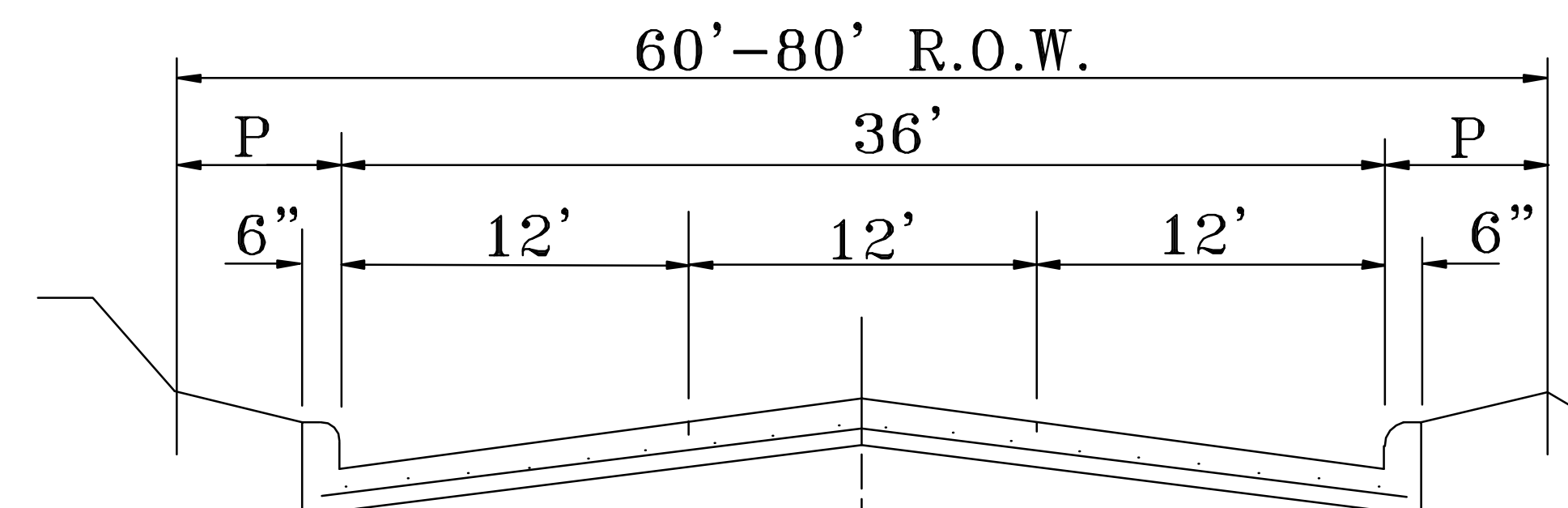

THREE LANE COLLECTOR
TYPICAL SECTION
CENTER TURN LANE
ONE LANE EACH DIRECTION
N.T.S.



2620 County Road 1106 | Anna, Texas 75409-5817
P 972.924.2757 | F 972.924.4053

City of Melissa

Road Capital Improvements
County Road 418 Expansion
Throckmorton Road to State Highway 121

PROJECT NO.	
DRAWN BY	GHG
CHECKED BY	SAH, RJH
DESIGNED BY	
REVISIONS	
ISSUE DATE	